

ITEM	DESCRIPTION	QTY	SPECIFICATION
1	Hydraulic Power Pack	1	1.5kw, 3ph/400v/50hz, 7L Tank, 4.2cc/rev Pump, 210 Bar Release Valve, 24vdc 'Energise To Lower' Solenoid Valve.
2	Flow Control Valve	1	Freeflow Check
3	Flow Divider/Combiner	1	Rotary 2.11/2.11 cc/rev, BSP Ports
4	Lock Valve	2	24vdc, 'Energise To Lower'
5	Cylinder	2	80 Bore, 40 Rod, 25mm (1") Forked Clevis Both Ends, Stroke + 315 = Closed Centres.

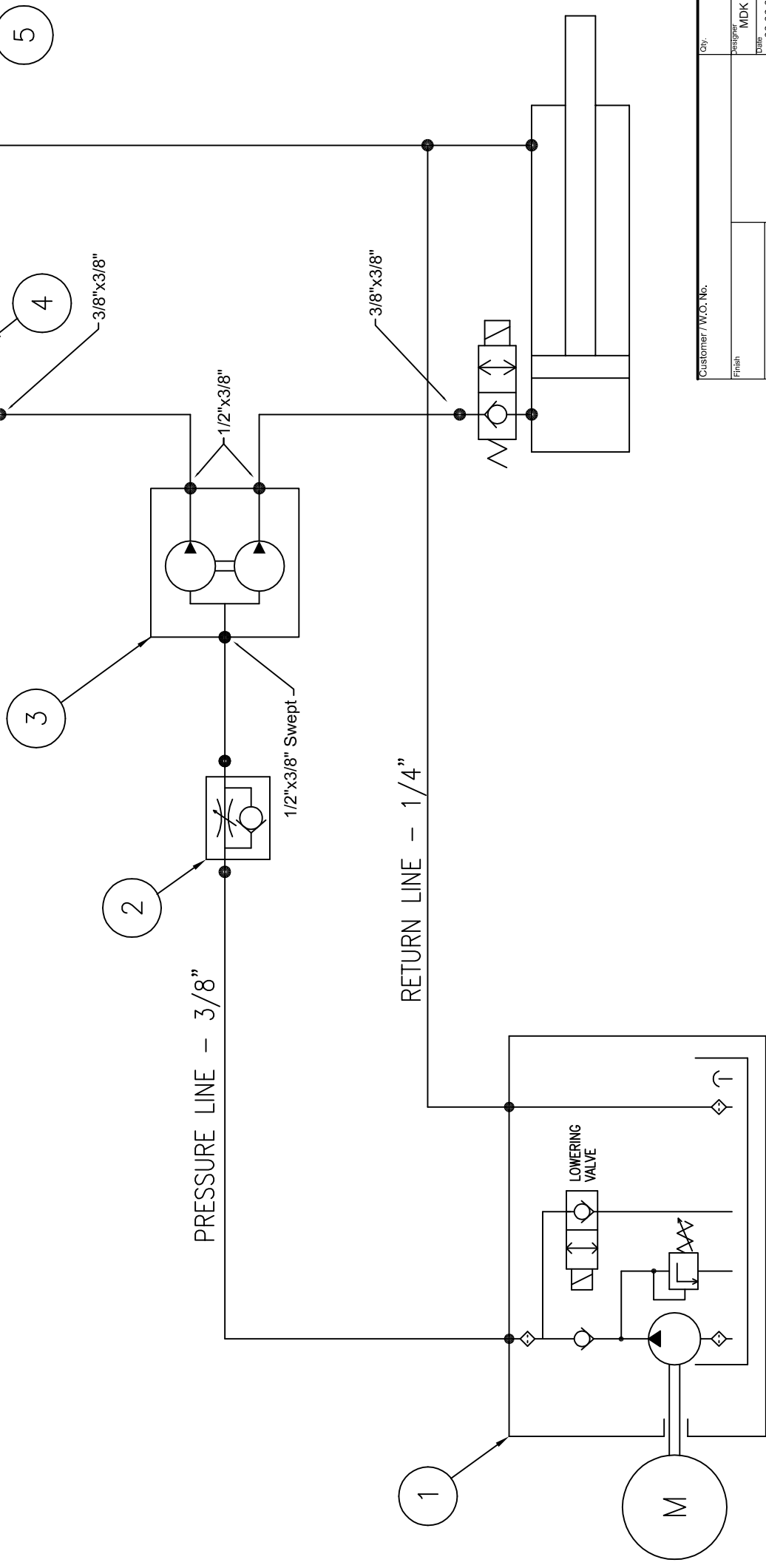

Best Conveyors
 Brunel Road
 Eastreps Industrial Estate
 Condy, Northants NN16 9JW
 Tel: +44 (0)1536 208066
 Fax: +44 (0)1536 208805
 Website: www.bestconveyors.co.uk

Unless otherwise noted
 dimensions are in millimetres.
 Remove all burrs and sharp edges
 Fraction Tolerance : ± 0.2mm
 Decimal Tolerance : ± 0.05mm

This print and all information
 contained hereon is property of
 BEST CONVEYORS,
 and shall not, wholly or in part, be
 copied, reproduced, or used by a third
 party, without expressed written consent.

Customer / W.O. No. _____
 Designer: MDK
 Date: 03.06.08
 Approved By: _____
 Date: _____

Title: TILT HYDRAULIC SYSTEM
 Part No. 100444
 300 STROKE